

NO.	ITEM	SPECIFICATION	CONDITION
1	Rated Voltage	4.2V	
2	NO. of Phase	2	
3	Step Angle	1.8° ± 5%	
4	No. of Step per Revolution		
5	Resistance Per Phase	2.8 ± 10%	
6	Inductance Per Phase	4.8mH ± 20%	
7	Current Per Phase	1.5A	
8	Holding Torque	5.5Kg.cm	
9	Pull-in Rate		
10	Insulation Class	Class B	
11	Dielectric Strength	100Mohm	500VDC
12	Insulation Resistance		
13	Operation Temp Range	-20 ~ +40° C	
14	Storage Temp Range		
15	Detent Torque		
16	Rotor Inertia		
17	Stepping Accuracy		
18	Life		
19	Lead Wire	AWG22	
20	MFG of Terminal	N/A	
21	Weight	0.34Kg(Max)	

Rev.	Revision	Date
01	Update	9/2/2010

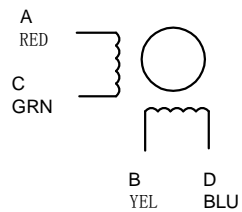
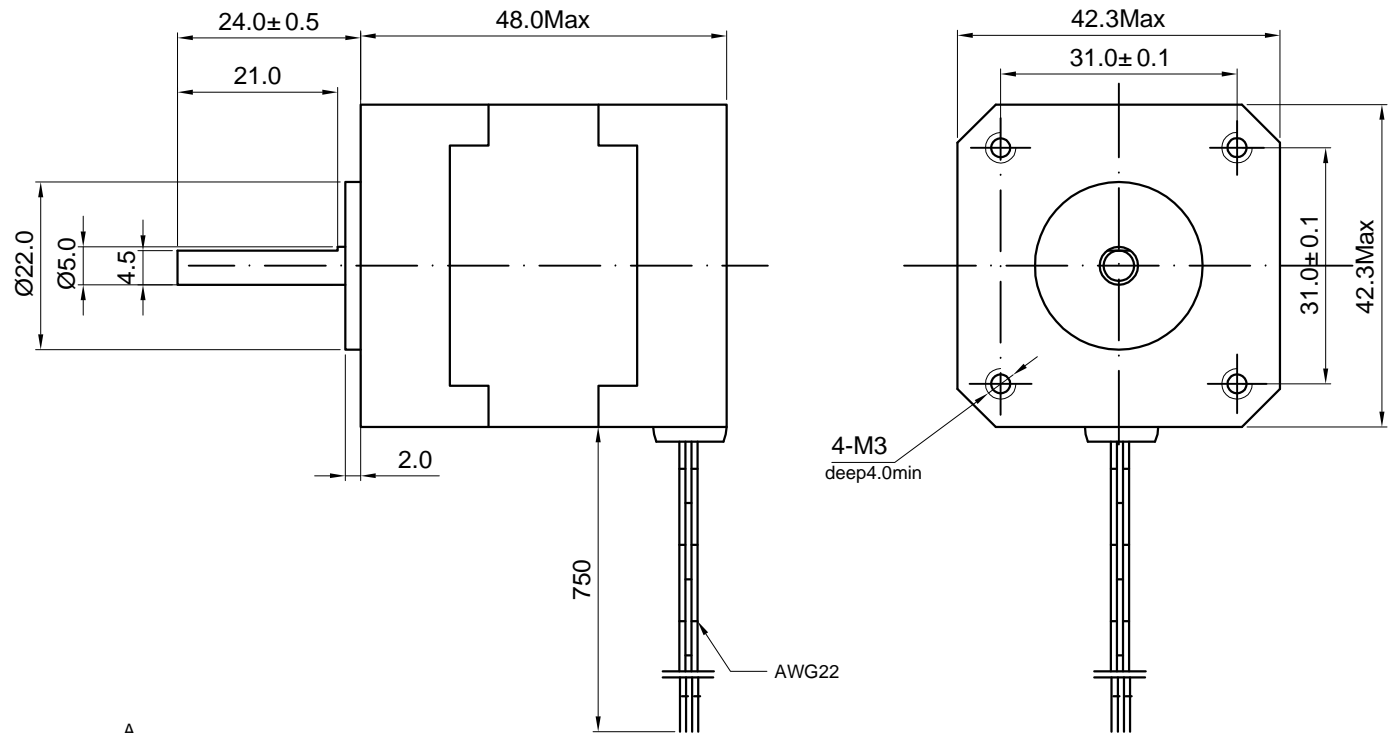

DRAWN	Ma Yunlei	9/2/2010	UNIT: mm		
CHECKED	Sara	9/2/2010			
ENG APPR.			Kysan Electronics		
MFG APPR.					
Q.A.					
42BYGH4803			SIZE A4	DWG.NO. 1504	REV 01
			SCALE: 1.5 : 1	Weight(kg): 0.34	SHEET 1 OF 1